



A POCKET REFERENCE

The 3D-Print Phrasebook

Plain words for asking AI to build the parts you want, the right way on the first try.

FOR GRANDPA FRANC & YOU

grandpacad.com/cheatsheet

Why a phrasebook?

Every craft has its words. Carpenters say *rabbit*; knitters say *purl*; mechanics say *chamfer*. When you use the right word, the listener stops guessing and starts building.

AI is the same. Ask for "a thingy with a hole" and you get a shrug in 3D. Ask for "an M3 counterbore on a 5 mm wall" and you get a part. This little book is the words.

It works for GrandpaCAD. It also works for any other AI tool that generates 3D models or CAD code, because the vocabulary is the same: a fillet is a fillet whether the underlying engine is JSCAD, OpenSCAD, Fusion, or a sculpting model.



Shapes & operations (pages 1–5)

The pure CAD building blocks. Primitives, transformations, booleans, and edge or face features: the moves every modeller strings together.



Designing real parts (pages 6–21)

Functional features, holes, fits, fasteners, joints, motion hardware, hot ends, electronics, gridfinity, and the filaments they print in. Hardware your design has to fit around.



Prompting & printing (pages 22–29)

How to describe a part so the model builds it: dimensions, references, multi-step builds, iteration. Then export and slicer vocabulary for getting it onto a bed.

Read it cover-to-cover or jump to the page you need. Either way, keep it within arm's reach.

For Grandpa Franc, who built me things.

CONTENTS

What's inside

● CHAPTER 1 Shapes & operations 01

- | | | | |
|----|----------------------|----|--------------------------|
| 02 | ● Primitives | 03 | ● Transformations |
| 04 | ● Boolean operations | 05 | ● Edge and face features |

● CHAPTER 2 Designing real parts 06

- | | | | |
|----|----------------------------------|----|----------------------------------|
| 07 | ● Functional features | 08 | ● Text and labels on parts |
| 09 | ● Holes | 10 | ● Fits and clearances |
| 11 | ● Fasteners | 12 | ● Nuts and threaded inserts |
| 13 | ● Joints for 3D printing | 14 | ● Printable connectors |
| 15 | ● Motion and 3D printer hardware | 16 | ● Belts, pulleys, and leadscrews |
| 17 | ● Electronics and panel mounts | 18 | ● Gridfinity bins |
| 19 | ● Filaments and materials | 20 | ● Sizes that print well |

● CHAPTER 3 Prompting & printing 21

- | | | | |
|----|------------------------------------|----|------------------------------|
| 22 | ● Organic models and images | 23 | ● Colors and textures |
| 24 | ● Dimensions and constraints | 25 | ● References and positioning |
| 26 | ● Multi-step builds | 27 | ● Iteration and corrections |
| 28 | ● Parameters and adjustable models | 29 | ● Hot end and extruder |
| 30 | ● Slicer vocabulary | 31 | ● Export and printing |

CHAPTER 1

Shapes & operations

The pure CAD primitives and operations. Stack them, combine them, and the rest of the design follows.

Primitives

The starting shapes for almost any design. Name them and you skip a lot of guessing.

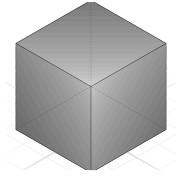

Cube / Box

A six-sided block. Width, depth, height in millimetres.

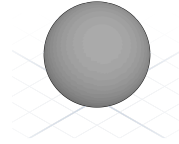

Sphere

A ball. Specify radius or diameter, not both.

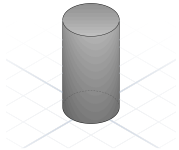

Cylinder

A tube or rod. Say hollow if you mean a pipe.

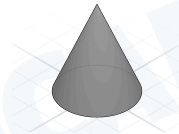

Cone

Tapers from a circle to a point. Truncated if it ends in a smaller circle.

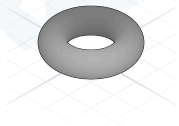

Torus

A donut. Give the ring radius and the tube radius.

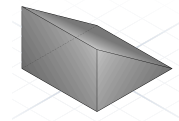

Wedge

A triangular prism. Ramps, brackets, and gussets start here.



Pyramid

Tapers from a polygon to a point. Square base by default.

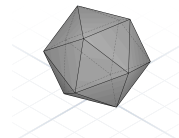

Polyhedron

A custom mesh from points and faces. Last resort when nothing else fits.

Transformations

How to move, turn, and reshape something that already exists. These compose, so order matters.

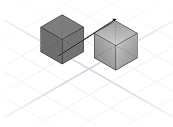

Translate / Move

Move along X (left/right), Y (front/back), or Z (up/down).

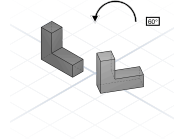

Rotate

Spin around an axis. Degrees unless you say otherwise.

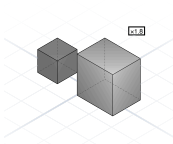

Scale

Resize uniformly or per axis. Per-axis turns a sphere into an ellipsoid.

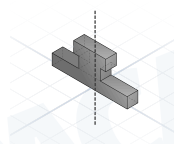

Mirror

Reflect across a plane. Good for symmetric parts.

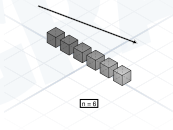

Linear array

Duplicate along a vector. Count and spacing, not "a few".

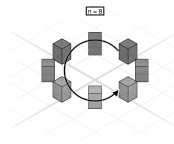

Circular array

Duplicate around an axis. Count and the full sweep angle.



Offset

Grow or shrink a shape outward by a fixed distance. Inflates or deflates a profile in place.

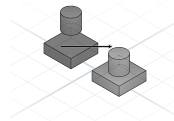

Align / Anchor

Snap one face, edge, or corner to another. Removes the math from "centre on top".

Boolean operations

Combine simple shapes to make complex ones. Most CAD models are booleans all the way down.

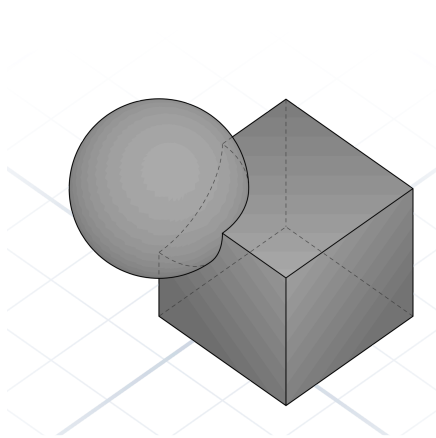

Union

Fuse two shapes into one solid. Overlapping volume becomes a single body.

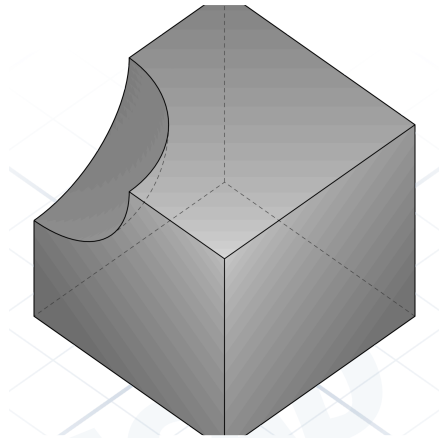

Difference

Subtract one shape from another. The way you make holes and cutouts.

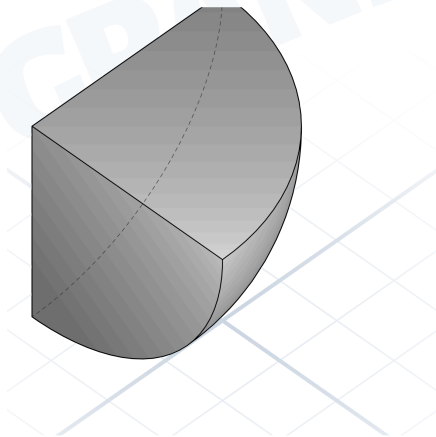

Intersection

Keep only the overlapping volume. Useful for trimming to a bounding shape.

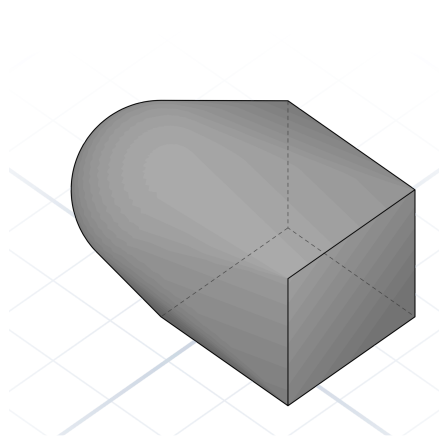

Hull

Wrap a tight skin around a set of shapes. Quick organic blends.

Edge and face features

Detail operations. These are what make a part look intentional instead of blocky.

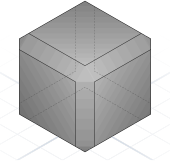

Chamfer

A flat cut on an edge, usually 45°. Eases insertion and breaks sharp corners.

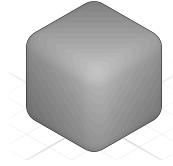

Fillet

A rounded edge. Stronger than a sharp corner, friendlier to touch.

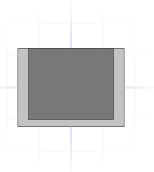

Shell

Hollow a solid, leaving walls of a given thickness.

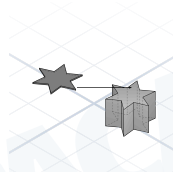

Extrude

Pull a 2D profile into 3D. The fastest path from sketch to volume.

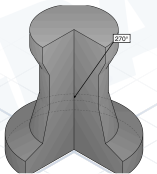

Revolve

Spin a 2D profile around an axis. Bottles, knobs, and vases come from here.

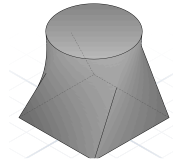

Loft

Blend between two or more profiles. Smoothly changes cross-section.



Sweep

Drag a profile along a path. Pipes, handles, and grooves.

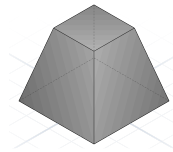

Draft / Taper

Slant a face by a few degrees. Helps prints release from supports.

CHAPTER 2

Designing real parts

How shapes turn into something printable: features, mating geometry, and the hardware your design has to fit around.

Functional features

Named shapes you add to a part to make it work: mounting, stiffness, sealing, or grip. Reach for them by name and the geometry follows.

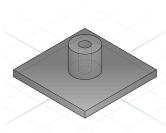

Boss

Cylindrical protrusion with a hole, usually for a screw or heat-set insert. The "where parts bolt together" feature.

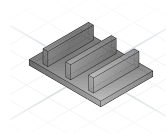

Rib

A thin reinforcing fin running along a surface. Stops a flat plate from flexing without doubling the wall thickness.

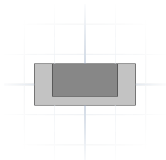

Pocket

Rectangular cavity in a solid. Cable channels, captive nuts, lightening holes.

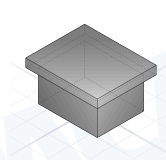

Lip / Flange

An edge that overhangs the wall below. The rim on a container, the mounting plate on a motor.

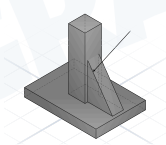

Gusset

Triangular brace between two perpendicular surfaces. Stiffens a wall without much material.

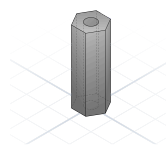

Standoff

Threaded pillar that holds something at a distance. Hex outside, M3 inside is most common.

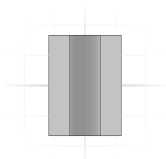

Spacer

Unthreaded sleeve that sets distance between two parts. The screw passes straight through.

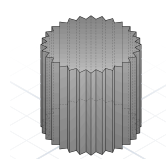

Knurl

Textured grip pattern on a cylindrical surface. Thumb screws and adjustment knobs use it so fingers don't slip.

Text and labels on parts

Five ways to put a name, number, or icon on a printed part. Pick by depth and whether you need a second colour.

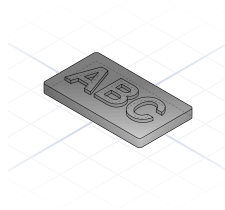

Raised text (embossed)

Letters rise ~1mm above the surface. Cleanest to print and easiest to read. The default when one colour is fine.

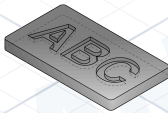

Sunken text (engraved / debossed)

Letters cut ~1mm into the surface. Robust against wear and scuffing, the go-to for serial numbers and stamped marks.

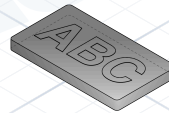

Flush text (multi-material inlay)

Pocket refilled with a second filament at the exact same height. Needs an MMU or a manual colour swap. Reads like a printed sticker.

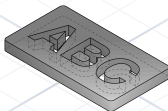

Through-text (stencil / cutout)

Letters cut all the way through the plate. Perfect for signage that lets light through. Closed loops like "O" or "A" need a bridge or they fall out.

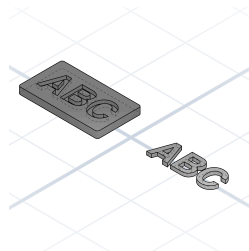

Segmented inlay (two-part assembly)

Print a plate with a text-shaped pocket and the letters as a separate piece. Glue them in a contrasting colour. Single-extruder friendly.

Holes

Not all holes are equal. The right name avoids a redesign cycle later.

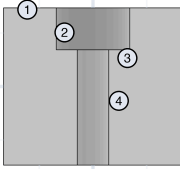

Anatomy of a counterbore

- ① Mating face
- ② Counterbore
- ③ Shoulder
- ④ Pilot hole

Naming the layers makes the prompt unambiguous:
"M3 clearance, 6mm counterbore, 3mm deep".



Through hole

Goes all the way through the part.



Blind hole

Stops at a depth. Say "blind, 8mm deep".

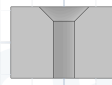

Countersunk hole

Cone-shaped recess so a flat-head screw sits flush. The chamfer angle matches the screw head (usually 90°).

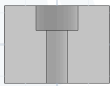

Counterbored hole

Cylindrical recess so a socket-head cap drops below the surface. Call the diameter and depth.



Spotface

Shallow counterbore that flattens a rough surface for a washer or bolt head to seat.

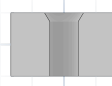

Clearance hole

Sized so a screw passes freely without engaging threads. Typically 0.2–0.5mm wider than nominal.

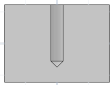

Pilot hole

Undersized hole for a self-tapping screw to cut threads into. Slightly smaller than the screw's nominal diameter.



Threaded hole

Has internal threads. Call out the size (e.g. M6). Printing usable threads is size-dependent: M2–M3 strips or blobs (skip it);...

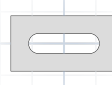

Slot

An elongated hole with rounded ends. Length and width, not just diameter.

Fits and clearances

How tight or loose two parts go together. Values are clearance on diameter for an average FDM printer; halve them when you offset per side in CAD.

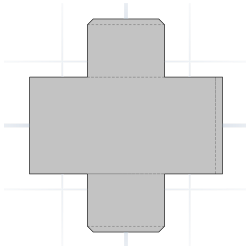

Press fit (interference)

Shaft is slightly bigger than the hole; needs a press or a mallet. Permanent: bearings, dowel pins. FDM: -0.1 to $+0.1$ mm on diameter. Add a chamfered lead-in so the shaft starts straight.

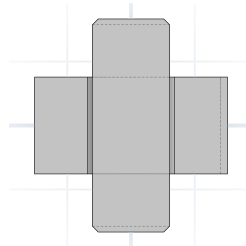

Transition fit

Assembles with light hand pressure (snug, but removable). Battery doors, sensor mounts, removable caps. FDM: $+0.1$ to $+0.2$ mm on diameter.

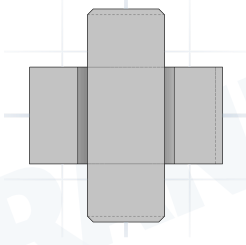

Sliding fit

Slides without wobble. Drawer rails, pistons, sliding lids. FDM: $+0.3$ to $+0.5$ mm on diameter (≈ 0.15 – 0.25 mm per side).

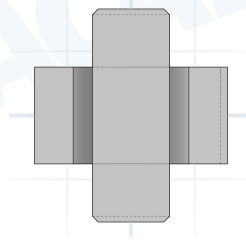

Clearance fit

Rotates or moves with a visible gap. Hinge pins, axles, bolt clearance holes. FDM: $+0.5$ to $+0.8$ mm on diameter.

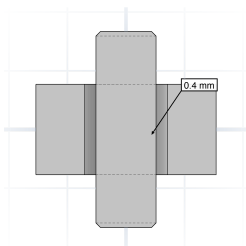

Loose fit

Easy assembly with room to spare. Cable pass-throughs, decorative covers, snap-on caps. FDM: $+0.7$ to $+1.0$ mm on diameter.



Calculator with the latest numbers

Scan for the live tolerance & fit calculator. FDM, SLA, and SLS values per fit type, scaled to your nominal dimension.

Fasteners

Screws and bolts you'll actually use on a printed project. Naming the head saves the redesign.

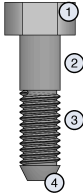

Anatomy of a bolt

- ① Head
- ② Shank (unthreaded)
- ③ Threads
- ④ Tip / Point

Pointing at the right part of the bolt tells the model which hardware to clear room for.



Cap screw (hex socket)

ISO4762 / DIN 912. The "M3x8" default in most printed projects.

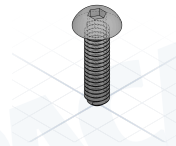

Button head

ISO7380. Lower profile than cap, same hex socket.

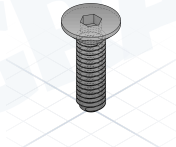

Countersunk (flat head)

ISO10642 / DIN 7991. Sits flush in a chamfered hole.

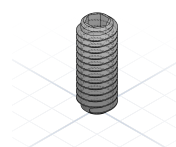

Set screw / Grub

Headless, threaded full length. Holds shafts to pulleys.



Self-tapping screw

Cuts its own thread as it drives. For printed parts, leave the pilot hole a touch smaller than the screw's nominal diameter.

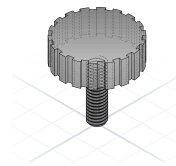

Thumb screw

Knurled head, tightened by hand. Good for tool-free assembly.

Nuts and threaded inserts

How you get a thread into printed plastic. Get the technique right and the screw holds for years.

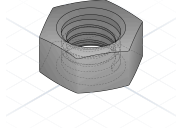

Hex nut

DIN 934 / ISO 4032. The default unless you say square or T-nut.

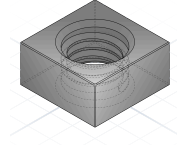

Square nut

Captive in a square pocket. Good when the back is unreachable.

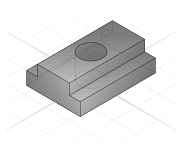

T-nut (extrusion)

Drops into 2020/3030 aluminium extrusion slots.

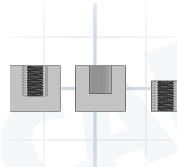

Heat-set brass insert

Soldering iron melts it into a printed boss. Strongest option for repeated screw use.

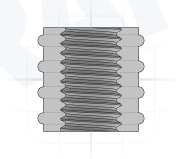

Press-fit insert

Pressed in cold. Knurled outside grips the plastic.

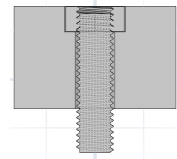

Captive nut pocket

A hex pocket printed into the part. Drop a standard nut in, screw from the other side.

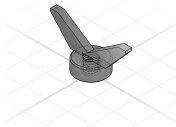

Wing nut

Tightened by hand. Good for parts that get opened often.



Thread & tap calculator

Scan for tap drill, clearance hole, and heat-set pilot sizes from M2 to M16, plus head dimensions for socket caps.

Joints for 3D printing

How printed parts attach to each other. These hold up without glue when the geometry is right.

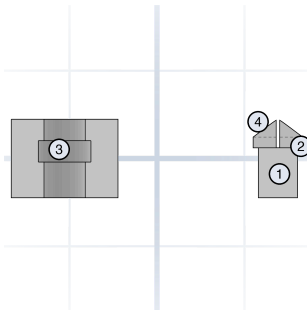

Anatomy of a snap fit

- ① Beam (flex arm)
- ② Hook
- ③ Catch / Undercut
- ④ Lead-in chamfer

Specify each piece and the model gets the deflection right. Beam thickness sets stiffness; lead-in sets ease of assembly.

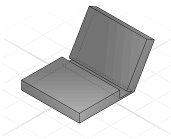

Living hinge

A thin strip (0.3–0.6mm) that flexes thousands of cycles. Orient layer lines across the hinge, never along it.

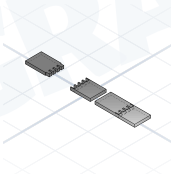

Tab and slot

A tab on one part drops into a slot on another. Cleanest joint for flat panels. Lock with glue or a screw.

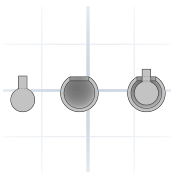

Ball and socket

Spherical ball in a partial socket. Print the socket about 0.3mm larger so the ball rotates freely.

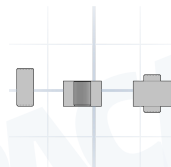
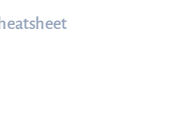

Press fit

Hole slightly smaller than the shaft. About 0.1mm interference for FDM. Add a chamfer to both parts.

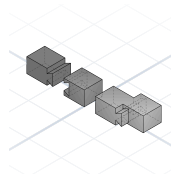

Dovetail

Trapezoidal profile that slides together. Self-aligning and captures one axis. Use 7–10° flare.

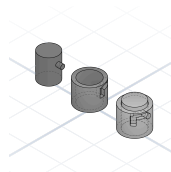

Bayonet lock

L-shaped slot. Push in, twist 90° to lock. The standard lid joint when threads are overkill.

Printable connectors

Library modules that snap, slide, or twist printed parts together. Drop them into a design and you've got a building system.

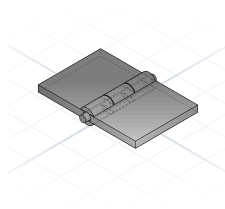

Knuckle hinge

Two leaves with alternating fingers (knuckles) that wrap around a steel pin. Print both leaves flat, slide a 1.75mm filament offcut through as the pin. 4mm knuckles print cleanly without supports.

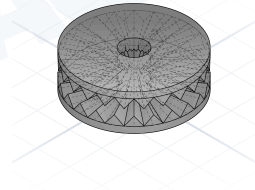
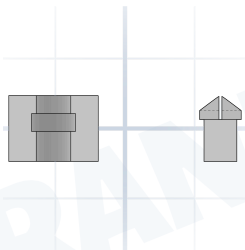

Snap pin & socket

A pin that pushes into a socket and clicks in place. The pin tip is split into four flexible petals that squeeze together on entry, then spring back behind a rim inside the socket. No screws...

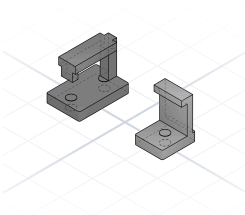

Snap latch

A flexible arm with a hook that catches on a lip. Press the tab and the hook lifts free. The everyday way to keep a printed lid closed without screws. 3mm arm thickness flexes thousands of times...

Hirth coupling

Two discs with matching radial teeth that lock together when clamped. Tighten a bolt through the centre, loosen and re-clock to set a new angle in fixed increments (15°, 30°). Used for...

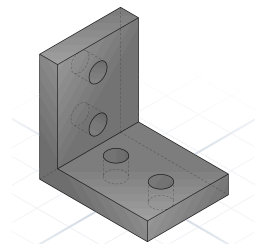

Corner bracket

90° L-bracket with mounting holes on both faces. Joins two panels at a right angle. Add a triangular gusset web on the inside if the load reaches kilograms.

Motion and 3D printer hardware

Off-the-shelf parts that show up in nearly every printer build. Reference them by size and the rest of the part designs itself.

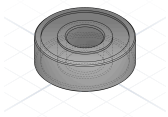

608 bearing

Skateboard bearing, $8 \times 22 \times 7$ mm. Spinners, idlers, friction-fit pulleys.

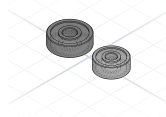

625 / 624 bearings

$5 \times 16 \times 5$ and $4 \times 13 \times 5$. The small idlers you'll see in printer kits.

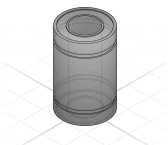

Linear bearing (LM8UU)

Recirculating ball bearing on an 8mm smooth rod. The standard linear-motion part.

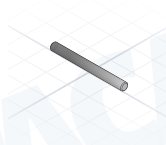

Smooth rod

Chromed steel shaft, usually 8mm. Linear bearings glide on it.

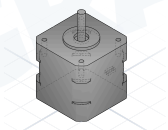

NEMA 17 stepper motor

42.3mm face, 5mm shaft. Mounting holes on a 31mm square pattern. Say "NEMA17 mount" and the holes line up.

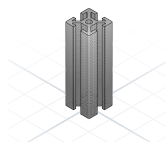

2020 aluminium extrusion

20×20 mm cross-section with a 6mm T-slot. The skeleton of most printer frames.

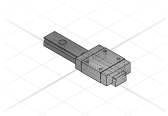

Linear rail (MGN12)

12mm rail with an MGN12H carriage. Stiffer and quieter than smooth-rod motion.

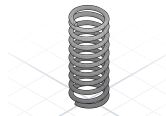

Bed-levelling spring

8mm OD, 20mm tall compression spring. The yellow ones under most i3-style beds.

Belts, pulleys, and leadscrews

The parts that turn motor rotation into linear motion. Name them by tooth count and pitch and the kit lines up.

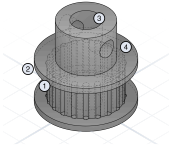

Anatomy of a GT2 pulley

- 1** Tooth profile (2mm pitch)
- 2** Flange
- 3** Bore
- 4** Setscrew hole

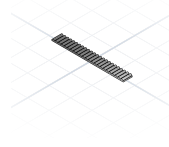

GT2 timing belt

2mm pitch toothed belt. 6mm wide is standard, 9mm for heavier carriages. Loop length matters, open belt is cut to size.

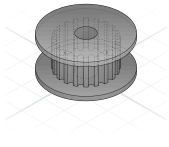

Toothed idler

Bearing with a GT2-toothed face. Reverses belt direction without the belt slipping on the wheel.

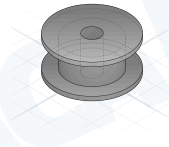

Smooth idler

Flanged bearing with a plain face. Used where the back of the belt rides the wheel.

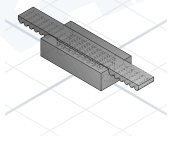

Belt clamp / tensioner

Printed block with a serrated slot that grips a GT2 belt by its teeth. Print the slot teeth at the same 2mm pitch as the belt, pinch with two M3 screws.



T8 leadscrew

Threaded rod built to drive a brass nut up and down. What separates it from a regular threaded rod is the steep trapezoidal thread and the lead: a 4-start T8 lifts 8mm per turn, ideal for Z-axes. Reach for ...

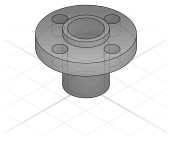

T8 brass nut

The mating nut for a T8 leadscrew. Bolts to a printed carriage on a 22mm flange pattern and turns leadscrew rotation into carriage motion. Anti-backlash variant has a sprung second nut for play-free...

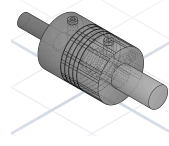

Flexible shaft coupler

Slotted aluminium tube that joins a 5mm motor shaft to an 8mm leadscrew. The cut slots flex to absorb misalignment so the screw doesn't bind.

Electronics and panel mounts

The boards, fans, and switches that need a printed home. Each has a fixed hole pattern: name the part and the holes follow.

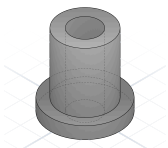

PCB standoff / boss

Printed pillar with an M3 heat-set or self-tap hole. State height, hole pattern, and whether the head sinks into a counterbore.

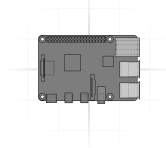

Raspberry Pi 4 mount

58 × 49mm M2.5 hole pattern. Say "Pi 4 mount" or "Pi 3 mount" (the patterns differ).

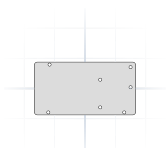

Arduino Mega / Ramps mount

M3 holes on the Arduino Mega footprint. Carries Ramps 1.4 control boards used in older printer builds.

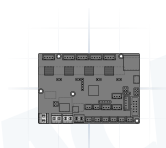

32-bit board mount

M3 hole patterns for BTT SKR Mini E3 or MKS Gen-L. Name the board revision; pinouts and mounting moved between versions.

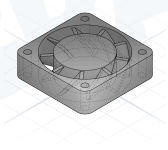

40mm axial fan

40 × 40 × 10mm. M3 holes on a 32mm square pattern. The hot-end cooling default.

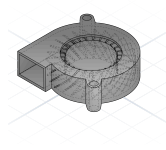

5015 radial blower

50 × 50 × 15mm centrifugal fan. Two M3 mounts and a rectangular outlet. The part-cooling default.

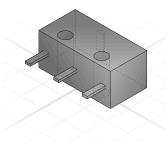

Microswitch (D2F-style)

Omron D2F endstop. 6 × 12.8mm body, two M2 holes 9.5mm apart. Used for X/Y/Z homing.

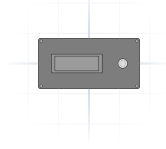

12864 graphic LCD

128 × 64 printer display with rotary encoder. Standard panel cut-out is roughly 150 × 75mm.

Gridfinity bins

A 42mm modular tray system. The real power is custom cutouts: print a bin shaped exactly for the tool it holds, then drop it on the baseplate.

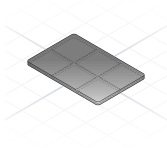

Baseplate

Tray with 42mm-pitch recesses that grip the chamfered foot of every bin. Bolt it to a drawer bottom and every bin has a home.

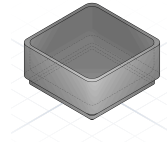

Single bin

The $42 \times 42 \times 21$ mm base unit. NopSCADlib: `gridfinity_bin("name", 1, 1, 3)` builds the shell, `gridfinity_partition()` hollows it.

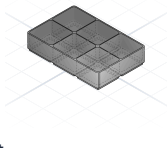

Multi-grid layout

Any rectangular footprint works: 2×3 , 4×1 , 5×5 . Pass (cols, rows, height) to the constructor; the baseplate stays the same.

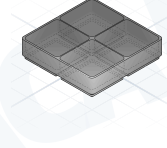

Partitioned bin

`gridfinity_partition(box, cols, rows)` hollows the interior into a grid of compartments. Four cells in a 2×2 bin sorts a kit of fasteners.

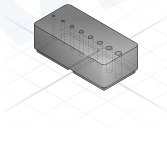

Drill-bit stand

Pass the cutout geometry as a child. A row of graduated cylinders gives every bit a labelled home. Copy the NopSCADlib `lathe_tool_stand.pattern`.

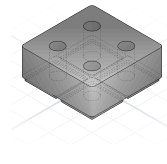

Tool stand

Bin with circular pockets sized for the tool shanks. Screwdriver bits, end mills, calipers: each one has a slot and won't roll around.

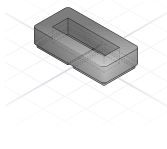

Custom pocket

Cut a single pocket shaped like the part it holds: micrometer body, multimeter, oscilloscope probe. The bin becomes a glove for that one tool.

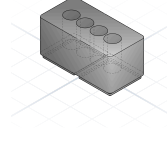

Cylinder rack

Tall bin with deep round holes. Markers, AA batteries, 18650 cells, paint pens stand on end and never roll off the bench.

Filaments and materials

What the part is printed in. Each has a sweet spot of strength, finish, and printability, and a temperature it gives up at.

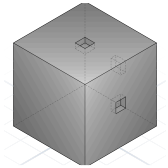

PLA

Easy everyday filament. Prints at 200°C, no enclosure needed. Stiff and accurate, but softens above 60°C, so don't leave parts in a hot car.



PETG

Tougher than PLA, semi-clear, water-resistant. Bottles, brackets, parts that need to flex without snapping.

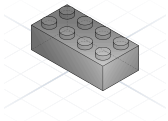

ABS

Durable and machinable (LEGO uses it). Needs an enclosure and ventilation; it warps and smells when printing.



TPU

Rubbery flexible filament, sold by shore hardness (95A is common). Gaskets, phone cases, dampers. Print slow with a direct-drive extruder.

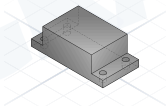

ASA

Like ABS but UV-stable. The right filament for parts that live outdoors.

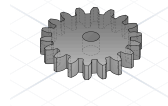

PC (Polycarbonate)

High strength and heat resistance (110°C+). Demanding to print: needs a hot end above 270°C and an enclosure.

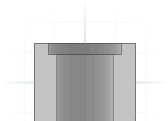

Nylon

Tough and slippery. Gears, bushings, living hinges. Absorbs moisture from the air, so dry the spool before printing.

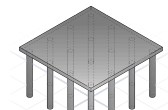

PVA support

Water-soluble filament for support material on a second extruder. Print, soak in water, the supports vanish.

Sizes that print well

Pick sizes that the printed plastic can actually hold. These are the defaults seasoned makers reach for.



Fasteners: M5 and up

M5 is the smallest size that grips printed plastic reliably. M6 for everyday brackets, M8 / M10 for load-bearing joints. M3 strips out at the first over-tighten, so skip it unless you're using a heat-set insert.

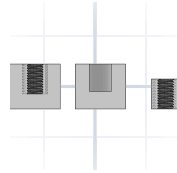

Heat-set inserts: M5 / M6

Brass insert melts into a printed boss and provides the threads. Design the boss at 8.5mm OD for M5, 10mm for M6. Thinner walls split when the insert melts in.

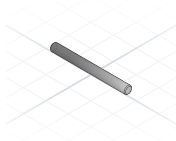

Linear motion: 8mm rod

LM8UU bearings, 8mm chromed rod. The whole ecosystem assumes this size: couplers, brackets, leadscrews all line up.

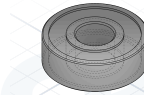

Bearings: 608 (8 × 22 × 7)

Cheap, plentiful, prints into a 22mm pocket with a 0.2mm interference fit. 624 / 625 work too; below 4mm bore is fragile.

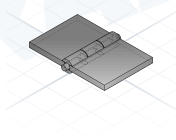

Knuckle hinge: 4mm × 1.75mm

4mm knuckle around a 1.75mm steel pin (offcut of filament works). BOSL2's knuckle_hinge() defaults. Smaller knuckles split; bigger waste plastic.

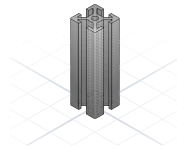

Frame stock: 2020

20 × 20mm aluminium extrusion with a 6mm T-slot. M5 T-nuts drop straight in. 3030 if you need more rigidity.

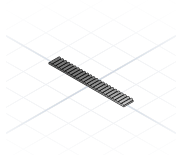

Belt: GT2 6mm

2mm pitch, 6mm wide. 16T or 20T pulleys on a 5mm shaft. Everything heavier than a print head wants 9mm width.

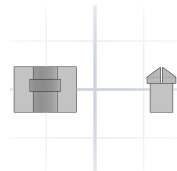

Snap pin: 7 × 11mm

7mm head, 11mm long total. The push-and-click connector between two printed parts. Replaces a screw on light-duty joints. Below a 5mm head the petals get fragile; above 10mm it's a screw waiting t...

CHAPTER 3

Prompting & printing

Talking to the AI, then handing the model to the slicer: what to say, and what to set before the nozzle moves.

Organic models and images

Not everything is a part. Ask for a creature, drop in a photo, or mix organic shapes into a CAD assembly — the AI picks the right engine.

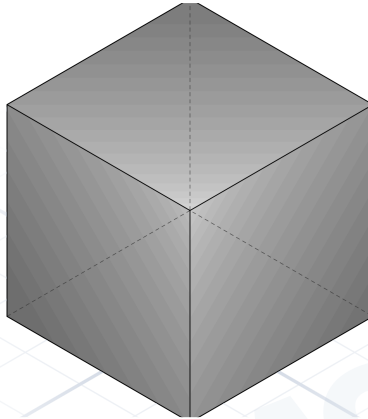

Ask for organic shapes

"A dachshund." "A small dragon." "A humanoid in a running pose." Mention a creature or character and the AI switches to the organic engine — no CAD primitives required. Catch: organic shapes don't expose parameters, so no sliders or knobs.

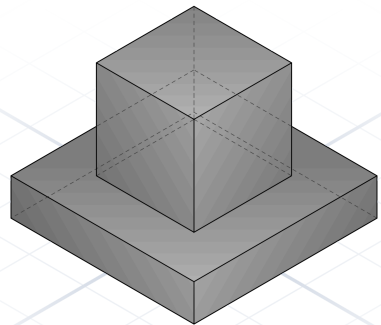
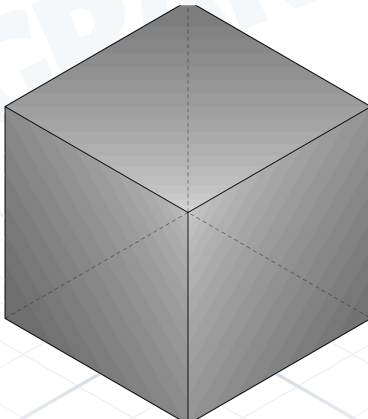

Image to 3D

Upload a photo of your dog, a sketch, or a reference picture. The AI builds a 3D model that mirrors the subject.

Mix organic with CAD

"A 10×10×3 mm pedestal with a dog dancing on it." The AI builds the geometric base and the organic figure together in one model. Bonus: the CAD half can still...

Colors and textures

How to ask for colour. Organic mode can texture or split the mesh into colour segments; CAD mode has no textures, but every part can take its own colour.

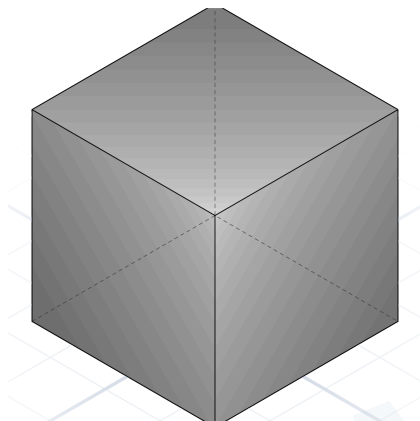

Textured organic shapes

"A dragon with scales." "A wooden stool with grain." The organic engine bakes the surface detail into the mesh — comes out as a coloured GLB you can render or display.

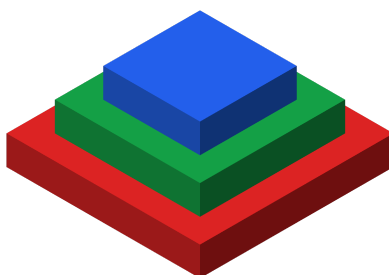
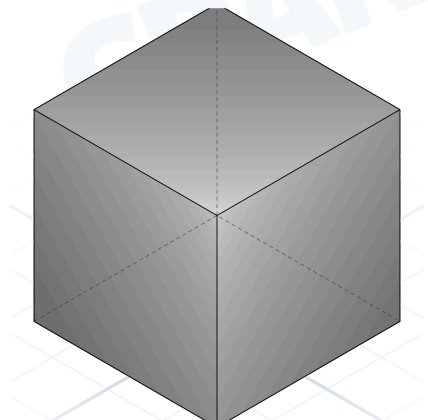

Colour segmentation

"Colour the dragon's wings red and body blue." The output ships as separate bodies, ready to paint per-region in a multi-colour slicer (AMS, MMU, Palette).

Colour CAD parts

CAD has no textures, but each part can take a colour tag. Useful for previewing, and slicers split each colour onto its own filament for multi-colour printing.

Dimensions and constraints

Numbers without context are guesses. Pin them down up front.

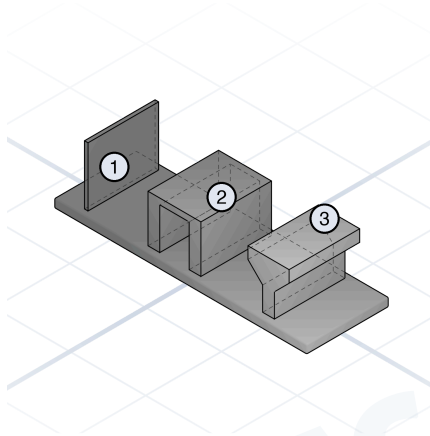

Mind printability

Walls ≥ 1.2 mm — anything thinner splits. Bridges of 2 mm and up span cleanly. Surfaces within 45° of vertical print without supports.

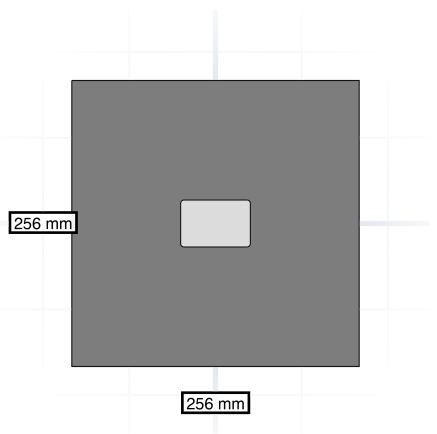
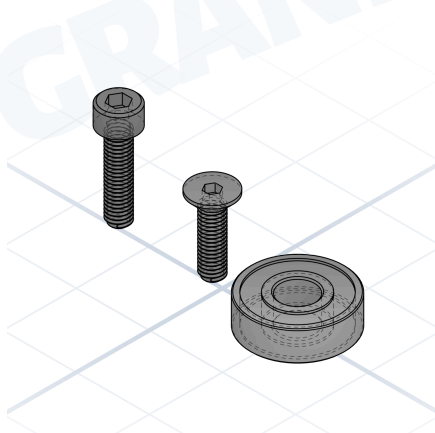

Cite standards

"M5 cap screw", "M5 countersunk", "608 bearing". The standard name carries every dimension — you don't have to spell them out.

Constrain the envelope

"Fits a 256 × 256 mm bed." A stated build plate stops the model from drifting to absurd sizes.

References and positioning

Where something sits is half the description. Anchor every part to something concrete.

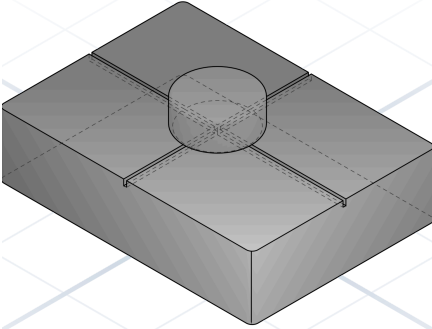

Anchor to a face or edge

"Centred on the top face" is unambiguous. "Near the top" is not.

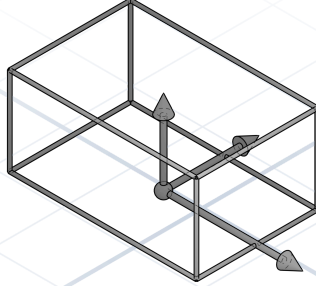

Pick an origin

State where (0,0,0) is. Bottom-centre is the most printer-friendly default.

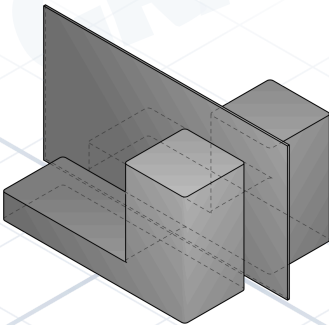

Reference planes

"Mirrored across the XZ plane" gives the model a fixed coordinate to anchor every feature to.

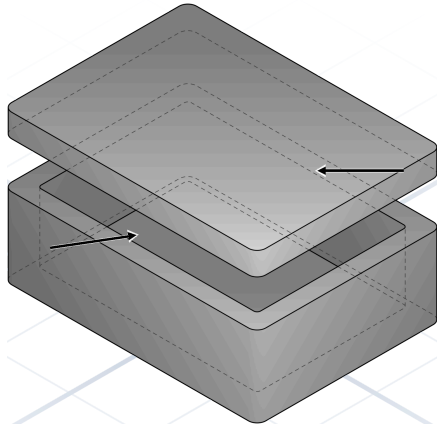

Mating surfaces

Name which face touches what. "The lid sits on the rim of the box, not inside it."

Multi-step builds

Complex parts come out cleaner when you give the model a plan, not a paragraph.

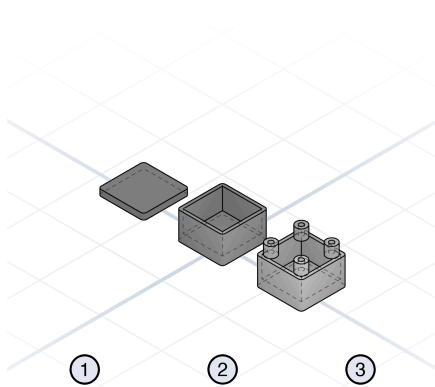

Outline the steps

"First the base, then the walls, then four mounting bosses." Order is information.

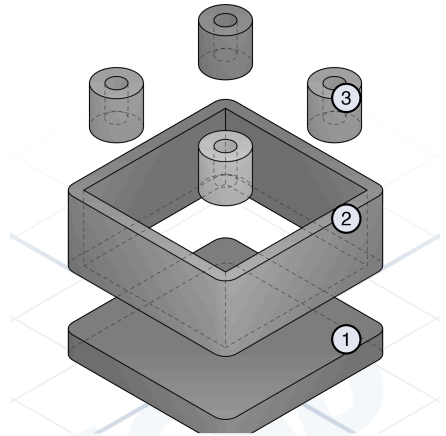

Name each part

Named parts give you something to point at when you iterate.

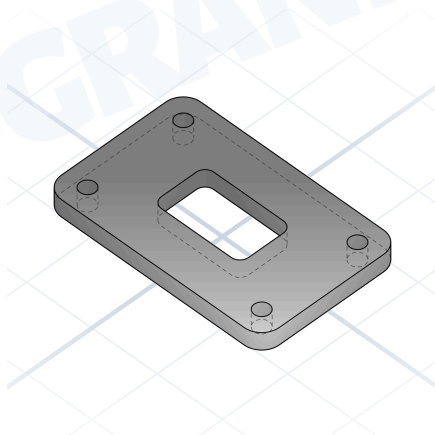

Build the base first

Get the silhouette right before adding details. Features attach to a stable foundation.

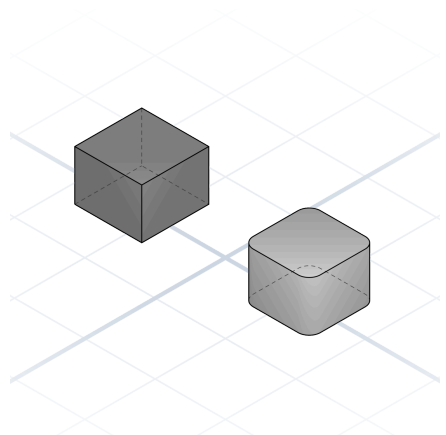

Add details last

Fillets, chamfers, logos. Cheap to add and cheap to take away.

Iteration and corrections

The first generation is rarely the final one. Good fixes are specific and surgical.

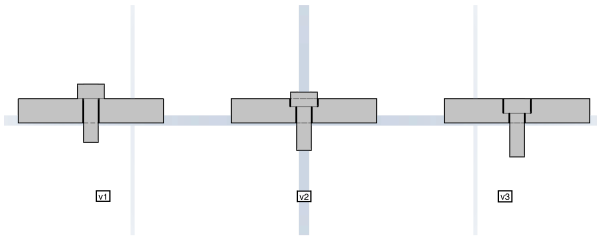

Describe the symptom, not the fix

"The screws stick out 1mm" tells the model what to solve. Let it pick the right tool instead of dictating the geometry change.

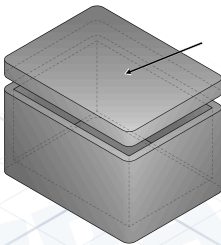

Point at one named part

"Make the lid 2mm thicker" lands. "Make it sturdier" wanders.

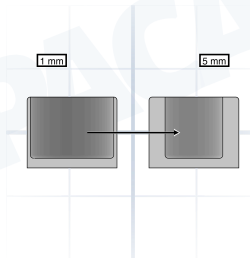

Give the exact change

"Change wall thickness from 1 to 5mm" leaves no room for interpretation.

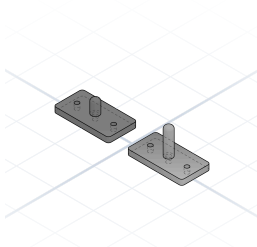

Say what to keep

"Keep the hole pattern as is" prevents a full redesign on every iteration.

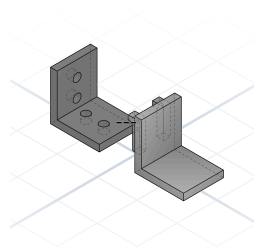

Try a different approach

When the model keeps drifting toward the same wrong shape, ask it to take a completely different approach. Resets the search.

Parameters and adjustable models

Expose the knobs you care about. Sliders, text, dropdowns, toggles — re-tune in place, no regeneration.

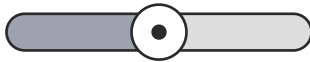

Sliders for dimensions

"Make wall_thickness a slider from 1 to 5mm, default 2." Use for any numeric input with a range.

Text for labels

"Add a name text parameter for the engraving." Single-line input—keychains, signs, name tags.

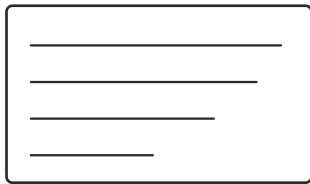

Textarea for paragraphs

"Make the back description a textarea." Multi-line input—dedications, addresses, longer labels.

Switches for features

"Add an include_lid checkbox." Toggle a hole pattern, a lid, a logo. No regeneration needed.

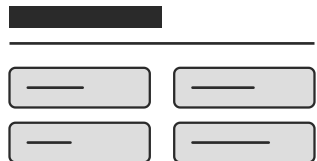
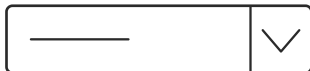

Dropdowns for choices

"Make the shape a select with options Cube, Sphere, Cylinder." Use when the answer is one of a fixed set.

Groups as section headings

"Put size settings under a Dimensions group and decoration under Style." Keeps long parameter lists tidy.

Hot end and extruder

The parts that melt and push filament. Naming the right segment puts mounting holes at the right offset from the nozzle tip.

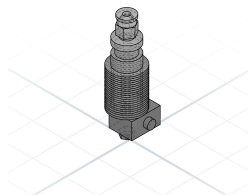
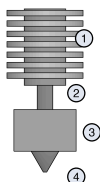

Anatomy of a hot end

- ① Heatsink
- ② Heatbreak / throat
- ③ Heater block
- ④ Nozzle

V6-style hot end

E3D V6 form factor: 12mm groove on the heatsink, M6 nozzle thread. The de-facto standard mount for printer carriages.

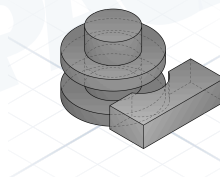
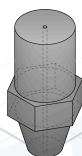

Nozzle

Brass or hardened steel tip, sized by orifice. 0.4mm is the everyday default; 0.6 / 0.8 for speed, 0.25 for detail.

Groove mount

The narrow waist between two flanges on top of a V6 heatsink. Print the carriage with a 12mm wide channel that damps the neck. No threads into the hot end itself.

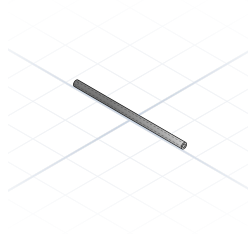
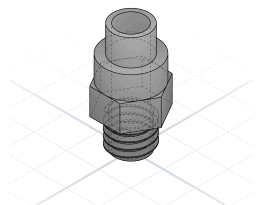

Bowden coupler

M6 push-fit fitting that grips a 4mm PTFE tube. Call it "push-fit M6" to stay vendor-neutral.

PTFE / Bowden tube

4mm OD, 2mm ID Teflon tube. Routes filament from extruder to hot end on Bowden printers.

Slicer vocabulary

The words the slicer uses. Knowing them lets you describe a part with the print step already in mind.

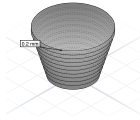

Layer height

Thickness of each printed slice. 0.2mm is the everyday default; 0.12mm for detail, 0.28mm for...

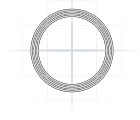

Wall / Perimeter

The shell loops around each layer. Three walls (~1.2mm) is the strength default.

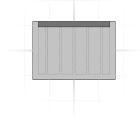

Infill

The internal lattice. 20% gyroid is fine for most parts; 80%+ for load-bearing.

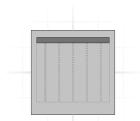

Top / bottom layers

Solid layers that close the part. Four to five layers stops infill from showing through.



Bridge

Flat span between two supports printed in mid-air. Up to ~30mm prints cleanly.

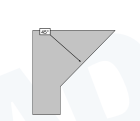

Overhang

A face leaning out from vertical. Above 45° usually needs support; below prints free.



Support

Scaffolding under overhangs, removed after printing. Tree supports use less material than grid.



Brim

Single-layer skirt fused to the part. Adds bed adhesion for tall or narrow footprints.

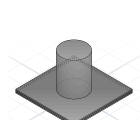

Raft

Sacrificial base layers under the part. Heavier than a brim; reach for it on warpy materials.



Skirt

A loose loop around the part, not touching it. Primes the nozzle before the real print starts.



Seam

The vertical line where each layer starts and stops. Hide it on a back corner with "Aligned" or "Random".

Export and printing

The model has to leave the page. A few habits keep parts printable on the first try.

STL • 3MF

Print orientation

Pick the right export

3MF preserves units and colour. STL is the lowest common denominator every slicer accepts.

Print orientation

Flat side down by default. Threads, holes, and engraved text want to face up.

+0.2mm fit

Avoid supports

Fit tolerances

Add 0.2mm to mating holes for press-fit, 0.4mm for slip-fit. Tune to your printer.

Design to skip supports

Chamfer overhangs to 45° and most prints don't need supports at all.

THANKS

For Grandpa Franc

When I was a kid he built me things from whatever was in the workshop. A wooden bazooka. A spinning top. A box that opened a particular way. None of it came with instructions. He just made it because I'd asked, or because he had fun doing it.

He's why I like making things. He's why this project exists.

Thank you, Franc.

IF THIS HELPED

Pass it along to someone just starting out. The vocabulary travels further than the lesson.

Feedback and corrections: grandpacad.com/contact



Now go build something.

The vocabulary in this booklet is what CAD designers use every day. Put it in your prompts and the model gets sharper on the first try.

The cheatsheet is free. The build is yours.



BUILD IT WITH US AT

grandpacad.com